











The SC001 electric vibrating system is perfect to guarantee an excellent cleaning of the product, discarding even the smallest impurities present in small leaf crops. The shaker is able to work both on board the vegetable picker and therefore operate directly during the harvesting phase, or work in a fixed position by connecting the shaker to the electric network by means of an inverter.

TECHNICAL FEATURES

	Control	Dedicated console with potentiometers with the possibility of electronic variation of the engine RPM
	Supply	Electric socket from 2P + T 16 A 48V.
	Conveyor belt motor	DC motor from 48V - 600W to 2500rpm IP67 with electronic speed variation
	Beater motor	DC motor from 48V - 240W to 3300rpm IP67 with electronic speed variation
	Conveyor belt	39X11 stainless steel trapezoidal mesh tape (with the possibility of reducing to 17.5 X11)
	Loading capacity	100 Kg
	Cutting width	From 1.200 to 1.800 mm (to be confirmed)
	Tare	From 220 to 360 Kg (in accordint to the cutting width)
	Recovery product	Drawer for the recovery of product waste
Selected products		

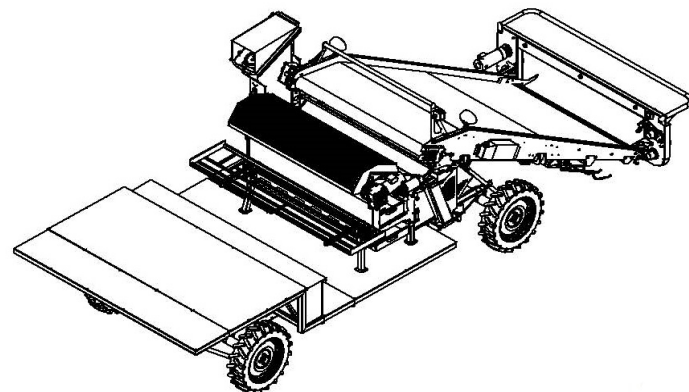
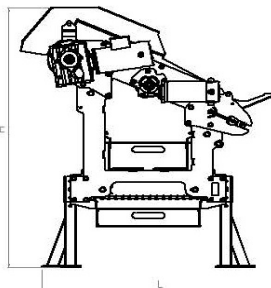
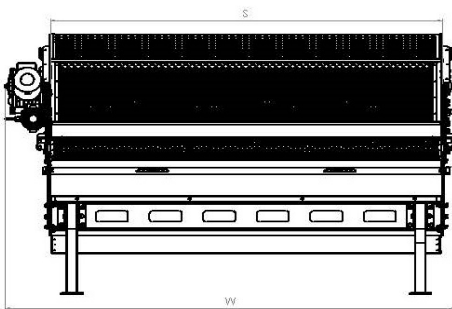

Larghezza taglio T	Larghezza selezione S	W	H	L
1500	1462	1680	1090	875
1600	1562	1780	1090	875
1700	1662	1880	1090	875
1800	1762	1980	1090	875